

VERTICAL BALER

6030HDB

Safety, quality and performance at a great price make the 6030HDB our most popular baler.

Wastequip's 6030HDB Baler is perfect for cardboard baling. It has a powerful 10HP motor, quick 45 second cycle time, and built-in forklift pockets. With a height under 8 feet, it fits under most doorways, and the 27" feed opening is the largest in the industry. Combined with an eye-level, side-mounted power unit, it's the perfect baler for operators, installers and service technicians. And, the best part is the great price for a baler packed with industry-leading features.

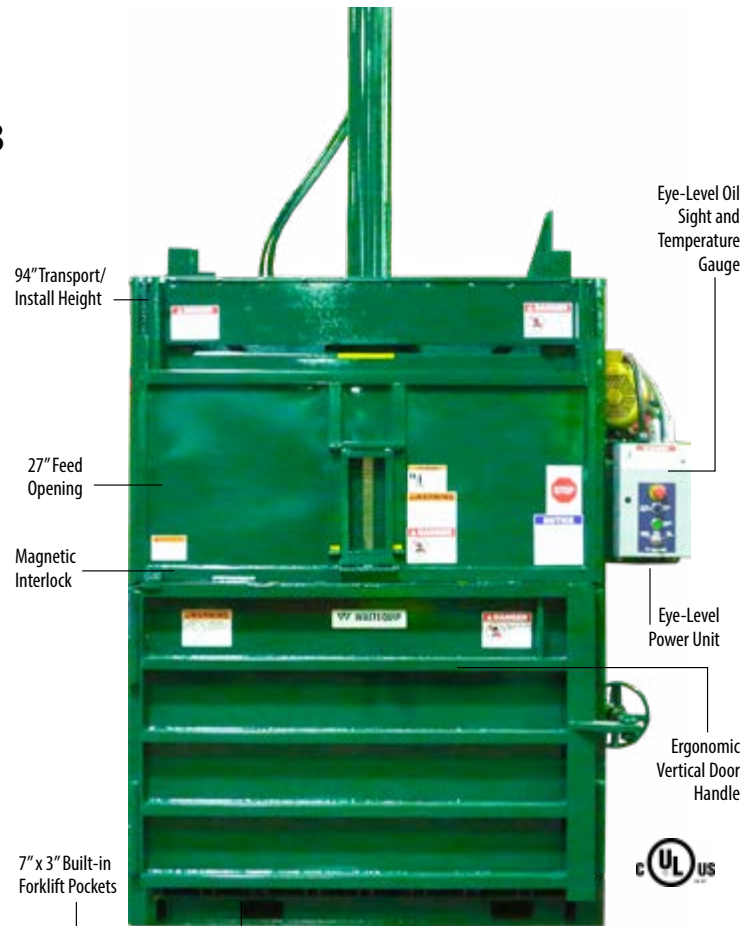

Value-Added Benefits

Easy to transport and install	<ul style="list-style-type: none">• Built-in forklift pockets for easier transport• 94" transport and install height fits vertically under most doorways
Easy to load	<ul style="list-style-type: none">• 27" feed opening is the largest in the industry
Fast and efficient	<ul style="list-style-type: none">• 45 second cycle time is one of the fastest in the industry
Easier to service and maintain	<ul style="list-style-type: none">• 10 HP motor eye-level, side-mounted power unit• Eye-level oil sight and temperature gauge provides visible indicator of oil volume, cleanliness and temperature to avoid repairs• UL listed solid state electronic controls• NEMA 4 control panel provides protection against windblown dust, splashing water and hose-directed water• High-performance HD32 hydraulic oil allows wider temperature operating range• High-quality, outdoor protective paint finish protects against oxidation and rust
Enhanced safety features	<ul style="list-style-type: none">• Auto Open Gate• Safety cable thru cylinder to protect in the event of cylinder pin failure• Emergency stop button• Front and rear retaining teeth stabilizes bale and increases density

VERTICAL BALER

6030HDB



Built-in forklift pockets allow for ease of transport and installation. Baler can be easily loaded on a standard flatbed by a forklift.

Specifications

CYLINDER BORE	6"
CYLINDER ROD	3.5"
CYLINDER STROKE	48"
MOTOR HP	10
PHASE & VOLTAGE	3 PHASE 208-230/460
BALE WEIGHT OCC	800-1,000#
BALE SIZE	60" X 30" X 48"
FEED GATE OPENING	27" X 60"
FEED HEIGHT	49"
PLATEN AREA (sq. inches)	1,725
PLATEN FORCE (lbs.)	56,500
OPERATING PRESSURE	2,000 PSI
CYCLE TIME (sec.)	45
CONTROL VOLTAGE	110 V
PUMP SIZE GPM @ 1850 RPM	13
SHIPPING WEIGHT (lbs.)	4,000

*Optional Features: bale wire guides, oil heater, and full bale light

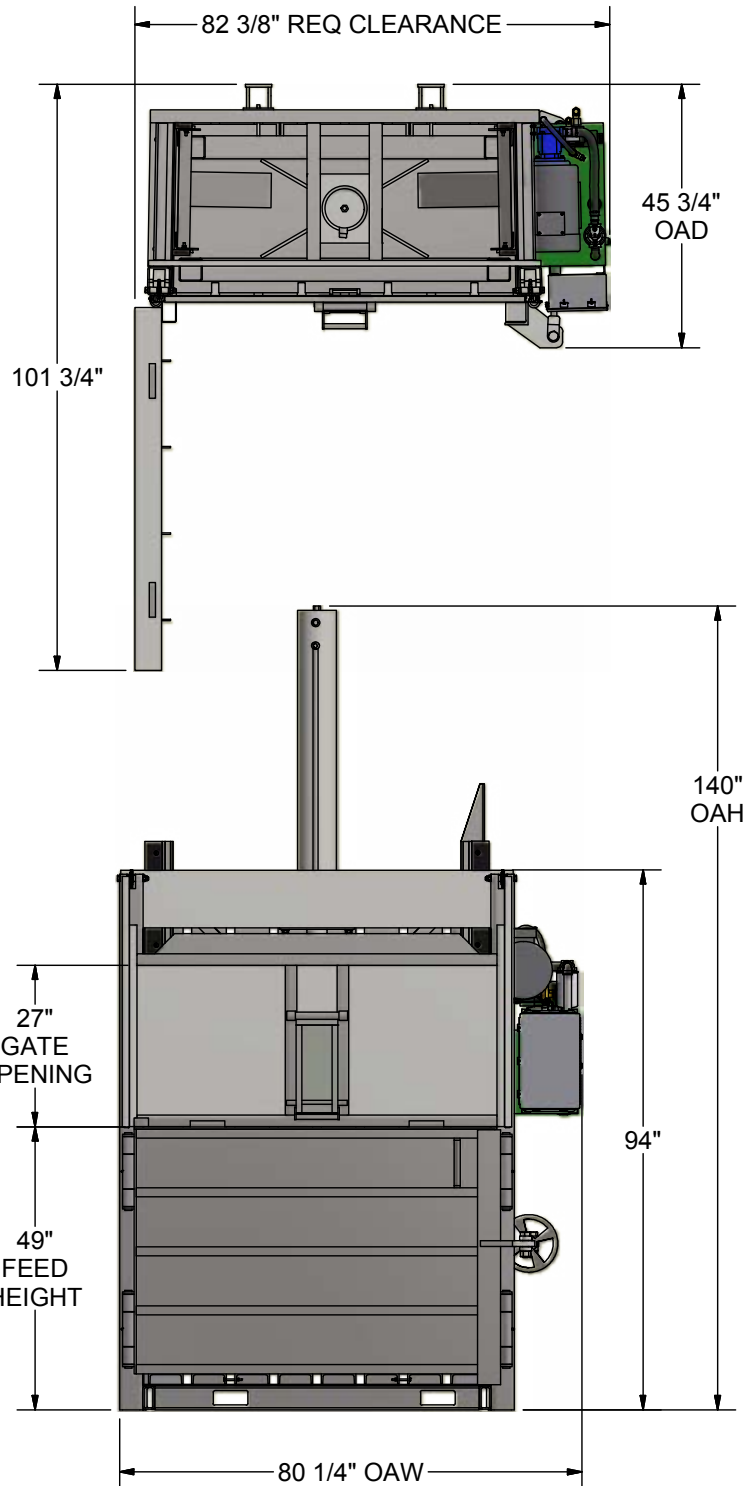

Tel: 877.468.9278 | sales@wastequip.com | www.wastequip.com

Wastequip is the leading North American manufacturer of waste and recycling equipment for collecting, processing, and transporting recyclables and solid or liquid waste. © Wastequip. All rights reserved. Specifications subject to improvement without notice. Equipment displayed should be operated by properly trained personnel. Operators should become familiar with OSHA, ANSI, and any other applicable standards or laws for using this equipment. Improper use, misuse, or lack of maintenance could cause injury to people and/or property. Photos used in the literature are illustrative only. We assume no liability or responsibility for proper training/operation of equipment not manufactured by Wastequip. We reserve the right to make changes at any time without notice. Information contained within this literature is intended to be the most accurate available at time of printing.