

# OPERATION, PARTS AND **SAFETY** MANUAL

 **SIGNODE®**

**TABLE-TYER / TABLE-TYER SS  
POWER STRAPPING MACHINES**

**IMPORTANT!  
DO NOT DESTROY**

It is the customer's responsibility to  
have all operators and servicemen  
read and understand this manual.

Contact your local Signode representative  
for additional copies of this manual.

***READ ALL INSTRUCTIONS BEFORE OPERATING THIS SIGNODE PRODUCT***

# CONGRATULATIONS

Thank you for purchasing your Table-Tyer Strapping Machine. The Table-Tyer has been designed to be a reliable, maintenance free strapping machine. The innovative design of this machine allows for every maintenance part to be replaced easily and quickly with very little or no instruction.

Considerable effort has been made to ensure that this product conforms to our high quality standards. However, should you experience any difficulties, please contact your Signode Representative with your machine model and serial number.

Thank you for your help.

CONTENTS	Page
Safety Information	3
Specifications	5
Major Components	7
Disconnect & Lockout	9
Electrical Schematic	10
Operation	12
Parts List & Views	15
Spare Parts	53

All conditions and options have been detailed in this manual to guide and alert operating and service personnel with respect to safety, operation and maintenance procedures. A complete parts listing, with exploded views, has been included in this manual in the event replacement parts must be ordered. Please review each section of this manual before operating your machine.

**PLEASE NOTE:** Most of the fasteners in this machine are metric. Before removing and replacing any part, refer to the parts listing to determine the proper tools to use and the correct size hardware that may have to be replaced.

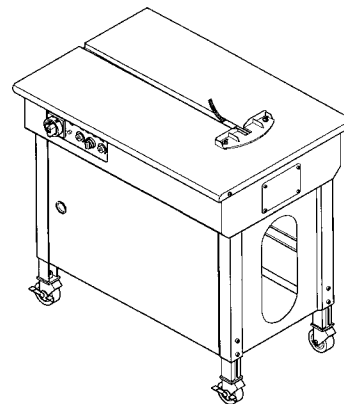

TABLE-TYER  
STRAPPING MACHINE  
PART NO. 500998

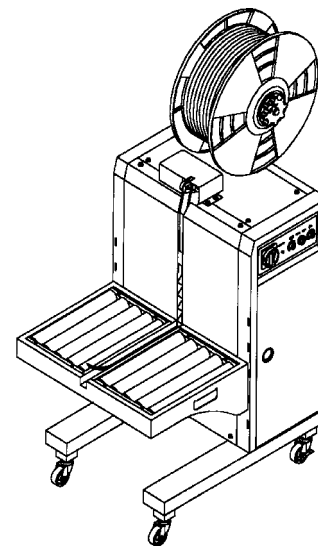

TABLE-TYER SS  
STRAPPING MACHINE  
PART NO. 500900

# **SAFETY INSTRUCTIONS**

**WARNING - READ AND FOLLOW THESE INSTRUCTIONS - FAILURE TO DO THIS COULD RESULT IN SEVERE PERSONAL INJURY.**

## OPERATING INSTRUCTIONS

1. Only people trained in the use of strapping machines are to operate or service this machine.
2. Read all signs on machine. Do not remove, modify or deface any sign. Replace all damaged signs.
3. Inspect the machine for unsafe conditions - DAILY - and replace all worn or broken parts.
4. Keep work area uncluttered and well lit.
5. If you require safety instructions in another language, contact your local Signode representative.

## MAINTENANCE

1. Establish a preventive maintenance program for your machine by following the preventive maintenance program in this manual.
2. To ensure proper machine operation, use the specified power sources listed in this manual.
3. Do not overload the machine by exceeding the package size specification.
4. Remove all packages from the machine before performing service.
5. Unless otherwise noted in this manual, disconnect and lockout all power before servicing your machine.
6. Follow all maintenance and service instructions in this manual.

## MOVING MACHINE PARTS



1. Disconnect and lock out all power to Signode's machines before entering the strap chute area.
2. Never put any part of your body into the strap chute area or machine enclosure with machine power on.
3. Never stand on the machine table-top.

## MACHINE INSTALLATION

1. All customer interlocks must be connected as shown in this manual's electrical drawings. Failure to properly connect interlocks can result in improper machine operation and/or personal injury.
2. Be familiar with the locations of safety interlocks/guards and Emergency Stop Devices - refer to machine manual topic "Disconnect & Lockout Procedures".
3. Do not defeat any safety interlock or safety device. Do not operate machine with any safety devices/guards removed.
4. Before operating the machine, ensure that all safety interlocks and Emergency Stop buttons are operating properly.
5. Unauthorized modifications can present a safety hazard to machine personnel and will void the machine warranty.
6. Secure the machine in place using the locking casters.

## PERSONAL PROTECTION



1. To prevent back or other body injuries, your employer must provide proper lifting and/or handling instructions. Your employer may also contact the National Safety Council, Itasca, IL 60143-0558 for information on lifting techniques.
2. When removing tensioned strap from a package, proceed as follows:
  - a. Wear eye, face and hand protection
  - b. Before cutting strap, make sure all personnel are at a safe distance.
  - c. Hold the strap against the load above the cutter as shown.
  - d. Using the proper Signode strap cutter, cut strap as pictured.
  - e. Stand clear of unheld strap end which will spring out if under pressure.
3. Always wear steel reinforced safety shoes.
4. Always wear safety glasses with side shields which conform to ANSI Standard Z-87.1 or EN 166
5. Wear protective gloves when handling strap.

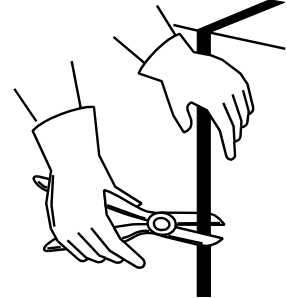

## ENVIRONMENTAL INFORMATION

The emissions produced during the heat sealing process may be an irritant to some people. Use this machine in areas that are externally ventilated. Should you be affected by these fumes, move away from machine to fresh air.

## LOCKOUT/TAGOUT



1. Follow OSHA 1910.147 (Lockout/Tagout Regulation) for machine lockout procedures and other important lockout/tagout guidelines.
2. Be familiar with all lockout sources on this machine, refer to the "Lockout & Tagout" section of this manual.
3. Even after a machine has been locked out, there may be stored energy in the system. To ensure that all stored energy is relieved, wait at least one minute before servicing electrical capacitors and wait 5 minutes for hot knife to cool.
4. Before performing service in the strap chute area, disconnect and lockout machine power.

## MOVING THE MACHINE

Wheel kits are standard for Signode general purpose machines. A forklift may be used to transport the machine from one location to another. Consult your employer for proper lifting and handling methods.

**TABLE-TYER, MACHINE SPECIFICATIONS**

<b>STRAP SIZES:</b>	Signode Empax 1/4" (6mm), 3/8" (9mm), 1/2" (12mm)	
<b>PACKAGE SIZE (Minimum):</b>	2"W x 1-1/2"H when equipped with the "Small Package Option"	
<b>VOLTAGE SPECIFICATIONS:</b>	Rated current:	3A
	Rated voltage:	110V
	Rated frequency:	60Hz
	Type of current:	AC
<b>FAULT PROTECTION:</b>	Fused	
<b>SYSTEM DISCONNECT:</b>	HP Rated switch	
<b>OPERATING HEIGHT:</b>	Minimum 30-3/4", Maximum 37-1/2"	
<b>WEIGHT:</b>	168 lbs.	
<b>NOISE EMISSIONS:</b>	55dB	
<b>MACHINE DIMENSIONS:</b>		

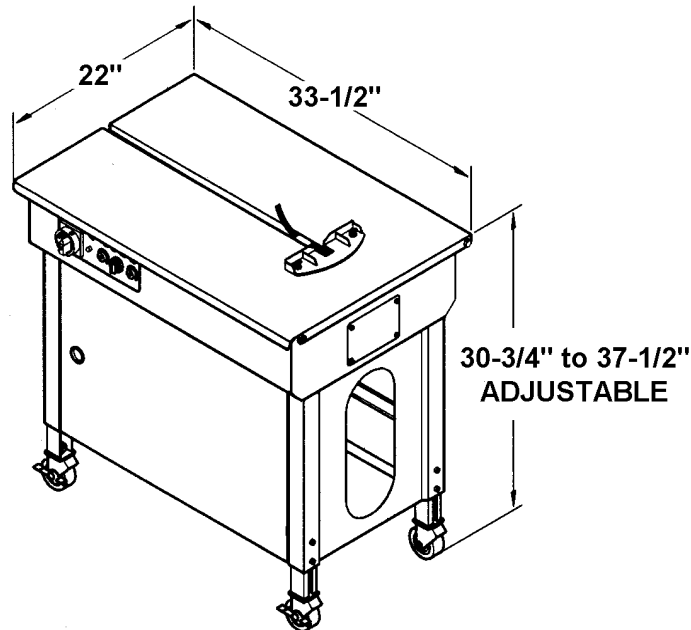

**TABLE-TYER SS, MACHINE SPECIFICATIONS**

**STRAP SIZES:** Signode Empax 1/4" (6mm), 3/8" (9mm), 1/2" (12mm)

**PACKAGE SIZE (Minimum):** 1-1/2"W x 3"H

**VOLTAGE SPECIFICATIONS:** Rated current: 3A  
 Rated voltage: 110V  
 Rated frequency: 60Hz  
 Type of current: AC

**FAULT PROTECTION:** Fused

**SYSTEM DISCONNECT:** HP Rated switch

**OPERATING HEIGHT:** Minimum 15-1/2", Maximum 27-3/8"

**WEIGHT:** 221 lbs.

**NOISE EMISSIONS:** 65dB

**MACHINE DIMENSIONS:**

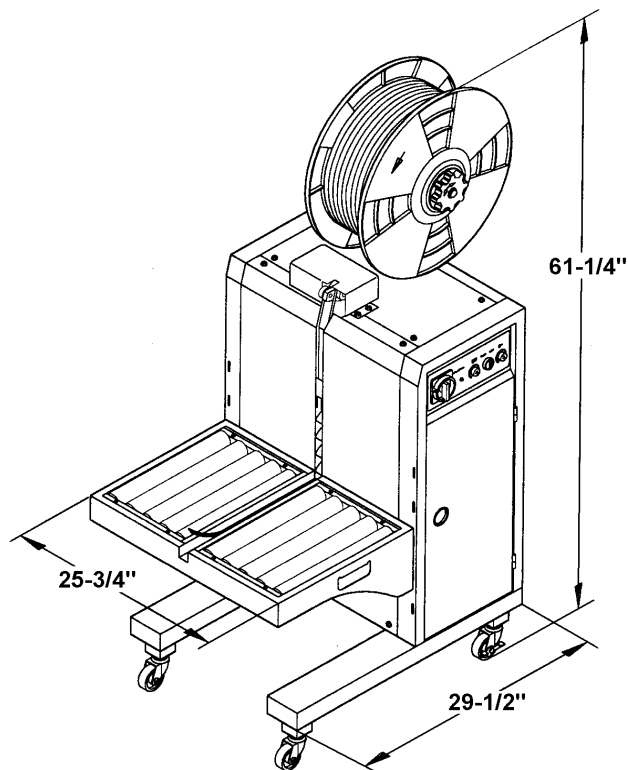

## MAJOR COMPONENTS - EXTERNAL

1. Main switch
2. Heater lamp, lamp will light on when proper sealing temperature is reached
3. Potentiometer, strap feed length
4. Button, strap feed and reset
5. Potentiometer, strap tension adjustment
6. Table top, hinge
7. Strap reel
8. Caster (2 locking)
9. Adjustable legs (Table-Tyer)  
Adjustable roller platform (Table-Tyer SS)
10. Frame
11. Access Door

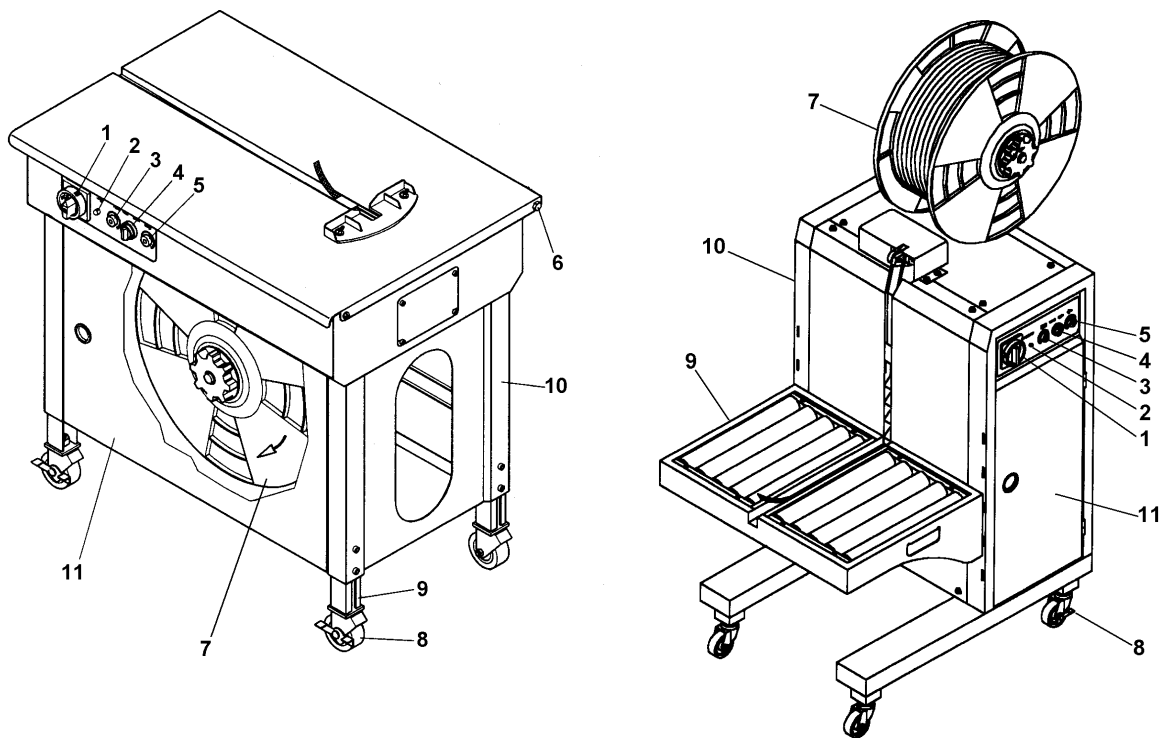

## MAJOR COMPONENTS - INTERNAL

QS1	Main switch
HL1	Heater lamp
R3	Strap feed length
R4	Strap tension adjustment
SA1	Button, strap feed and reset
SQ1	Switch, start
SQ2	Switch, home position
SQ3	Switch, Sealing position
AP1	P.C.B. Unit control
FU1	Fuse 115V, 3A (For power)
FU2	Fuse 1A (For P.C.B.)
FU3	Fuse 1 OA (For Motor)
FU4	Fuse SA (For Heater)
R1	Weld Cooling Timer
R2	Heater Temperature adjustment
SB1	Jog Switch
A1	High Tension Knob
A2	Feed Length Knob
A3	Heater Temperature knob
M1	Motor 1, unit drive
M2	Motor 2, strap feed and reverse
M3	Fan
I	Heating unit

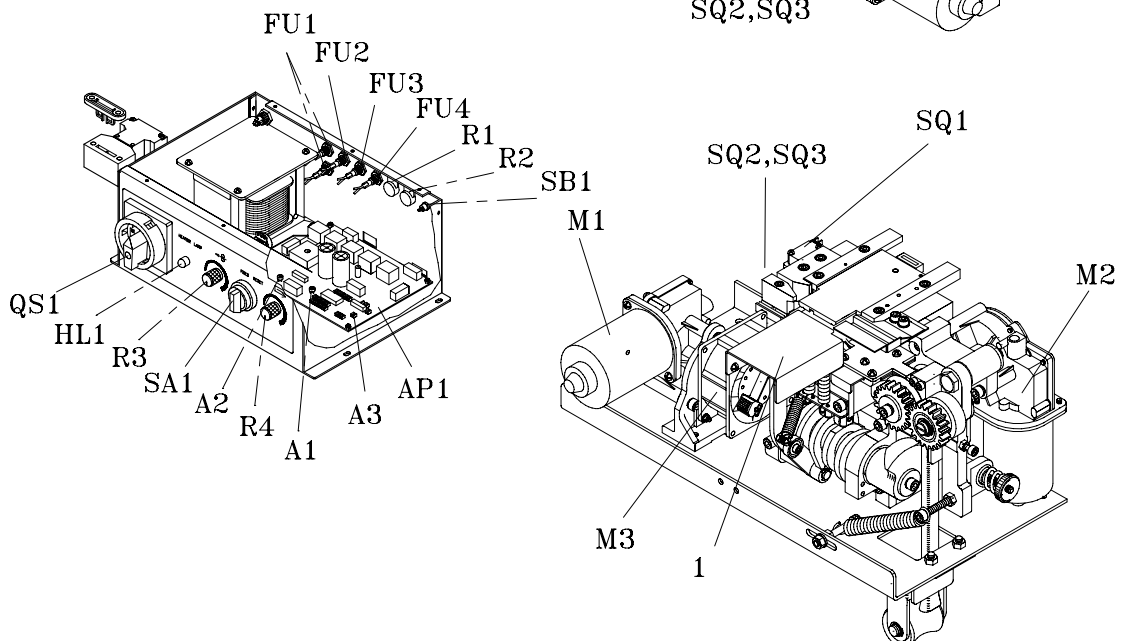
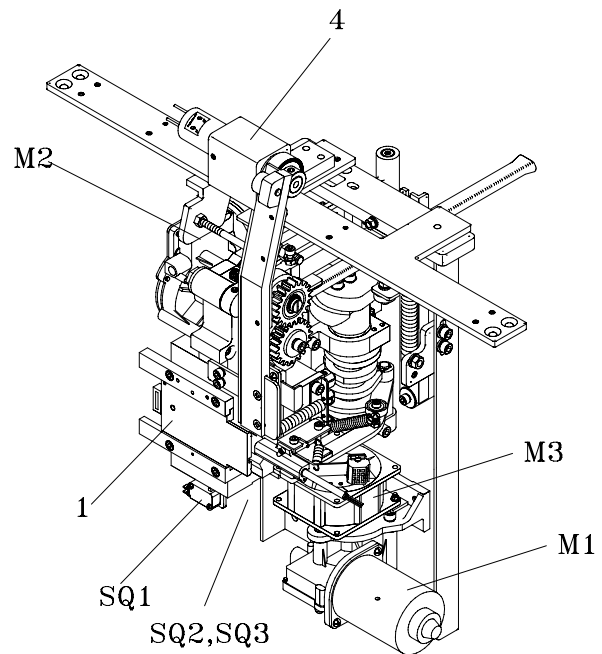



## MACHINE DISCONNECT AND LOCK-OUT PROCEDURES

This machine is equipped with shut off devices which satisfy OSHA Regulation 1910.147 (control of hazardous energy sources - lock out/tag out).

### **WARNING**

Become familiar with the location, and operation of each shutoff device.

Disconnect/Lock-Out all power sources before servicing machine.

Never use machine operating controls as a means for locking out power.

## ELECTRICAL

The machine is ready to operate when connected to the main power supply and the main switch QS 1 is switched to ON position. It takes approximately 1 minute for the heating element to reach its operating temperature.

The machine is switched on and off with the main switch QS 1 located on the machine front operating panel.

- Turn the main disconnect switch to the OFF position.
- Locate the appropriate locking hole on the switch, and apply a locking device.

**NOTE:** Some electrical components in the machine may be electrically charged after the power is shut off. Wait no less than one minute after the power has been disconnected before servicing the panel.

# ELECTRICAL SCHEMATIC, TABLE TYER

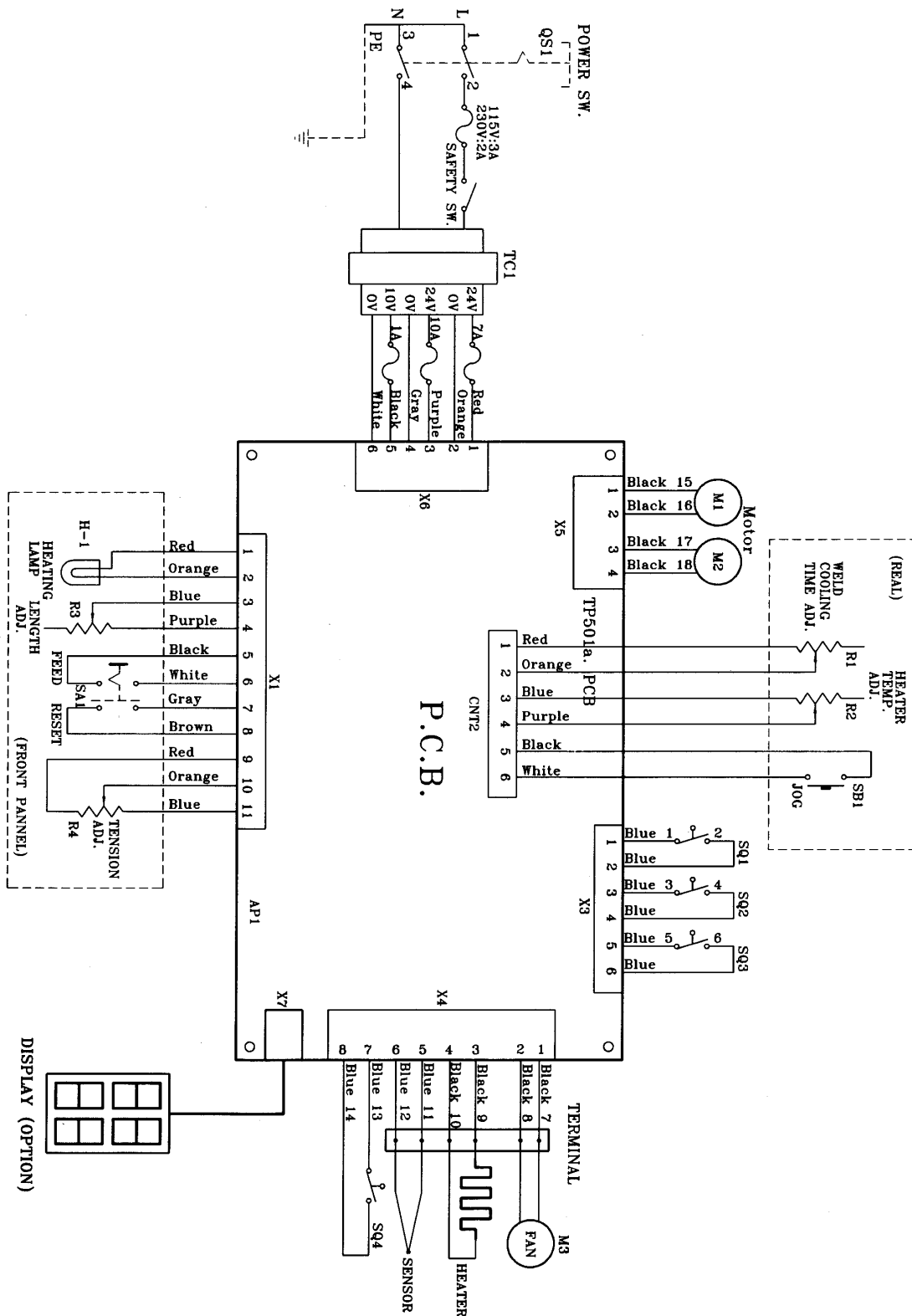

ELECTRICAL SCHEMATIC, TABLE TYER SS

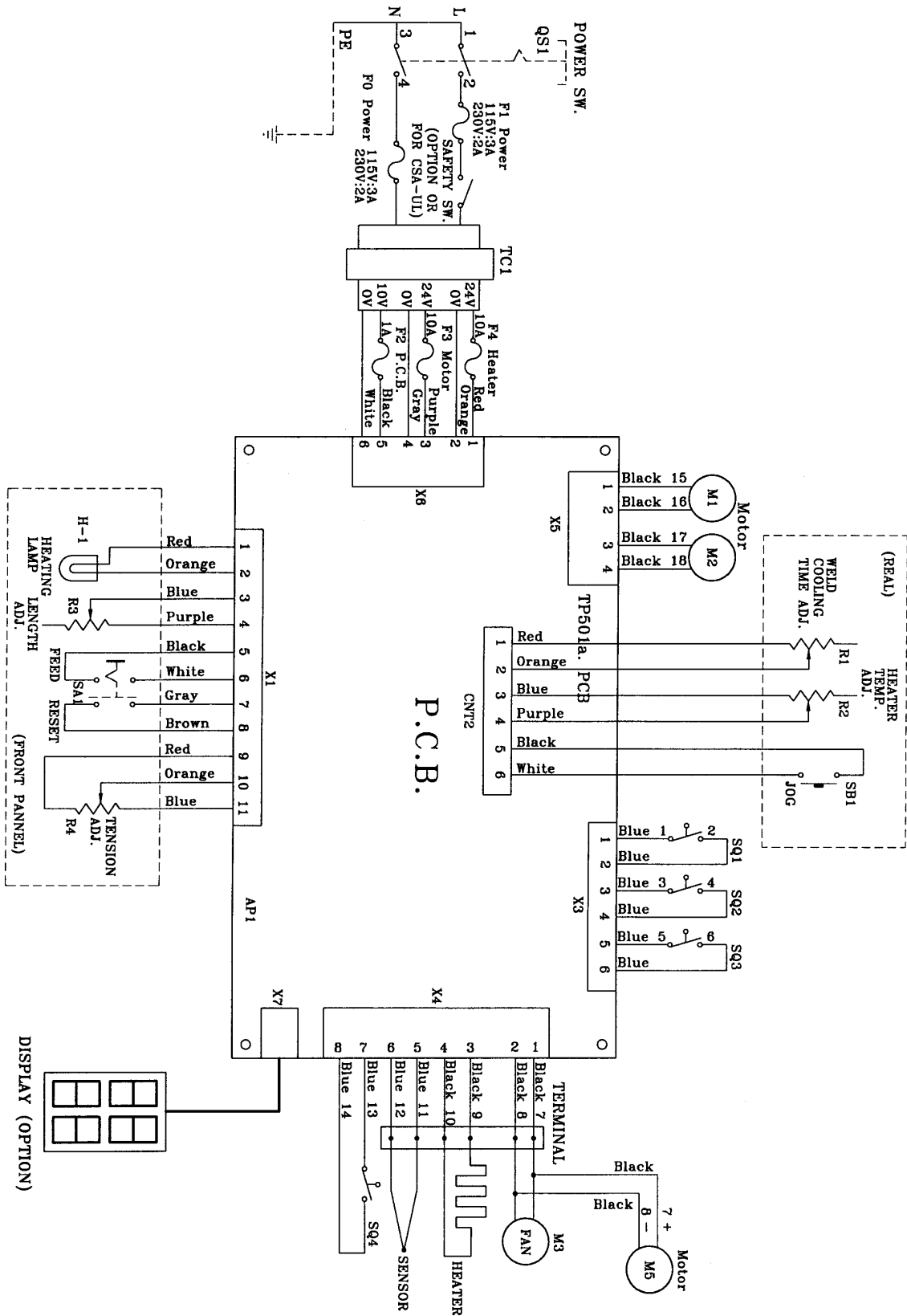

## MACHINE OPERATION

### START-UP AND OPERATING SEQUENCE

1. Put strap on the strap reel and thread the strap.
2. Turn main switch QS1 to ON. The heating element reaches the working temperature in approximately 1 minute.
3. Use potentiometer R3 to adjust the strap length.
4. Place the strap around the package to be strapped and insert the strap into the strapping head until it stops.
5. The strapping and welding sequence should complete.
6. At end of strapping sequence the strap end is fed automatically.
7. R4 adjusts the strap tension.

### THREADING STRAP

1. Turn reel nut handle (A) left and remove it.
2. Remove the cover of the reel (B) and install the strap reel.
3. Make sure that the payoff rotation matches directional arrows when unrolling.
4. Put the reel cover back on and tighten reel nut handle (A) to the right.
5. Remove all adhesive strips or other adhesive material.
6. Unroll about 1.5 m strap and make sure that it is not twisted.
7. Thread the strap in direction of arrow over (C) to roller (D). Continue to thread strap into rollers (E).
8. Turn left button SA1 (strap feed) until the length you need.

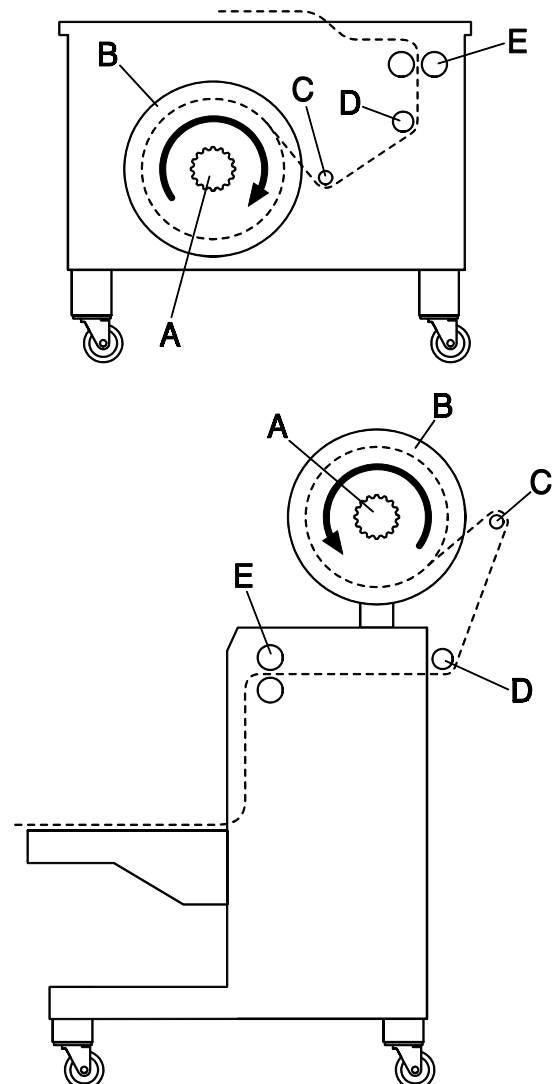
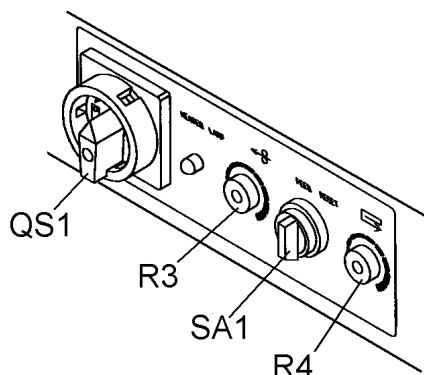

## STRAP TENSION

If R4 (strap tension adjustment) is on MAX position make sure that A is turned clockwise until the strap is not sliding between rollers B and C.

Reverse action to achieve lower strap tension.

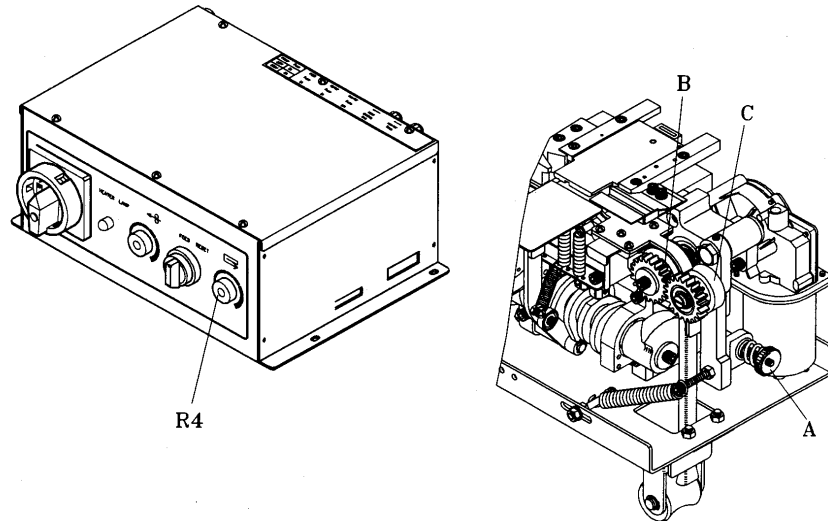

## MAINTENANCE AND LUBRICATION

To ensure that the semi-automatic strapping machine is always ready for proper and reliable operation keep to regular and attentive maintenance. Keep the machine clean and take care particularly of the strap guides. All small particles of loose strap should always be removed from all parts of the machine. In addition to the strap guides, the strap feed devices of the unit, the top of the dies and the feed devices on the strap magazine have to be blown free of any dust at least once per week. The dies on the unit have to be lightly lubricated weekly.

Lubricate the marked points weekly. Use only resin-free brand name oil for lubrication. All other assemblies are maintenance free. The strap guides and the sealing unit have to be kept clean! Do not oil feedrollers.

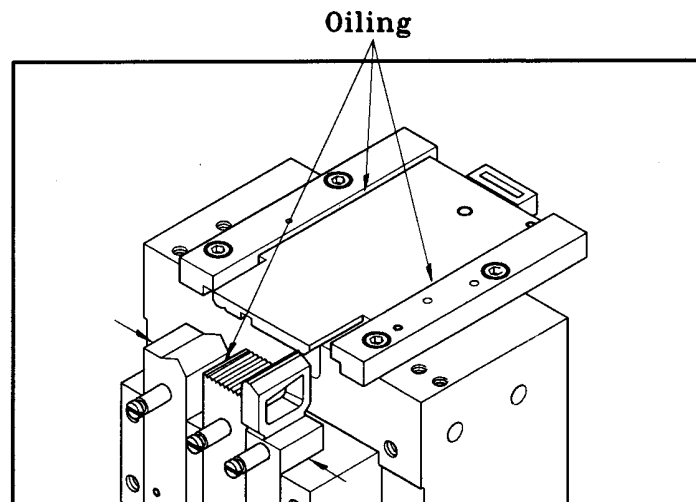

**BLANK**

**PARTS LISTS & EXPLODED VIEWS**

	Page
<b>INTERNAL GROUPS:</b>	
Control Head	16
Cam	18
Heater	19
Rear Bar	20
Press Bar	21
Front Bar	22
Feed	23
Main Roller	24
Feed Shooter	25
Roller Arm	26
Strap Guide	28
Transmission	29
Feeding Motor	30
Auto Loading	32
<b>EXTERNAL TABLE-TYER:</b>	
Frame	35
Base	36
Top Plate	38
Reel Unit	39
Reel Control	40
<b>EXTERNAL TABLE-TYER SS:</b>	
Frame	42
Reel Control	44
<b>ELECTRICAL:</b>	
Control Unit	47
Control Components	48
<b>OPTIONS:</b>	
Indicator Unit	52
Small Package	52
<b>SPARE PARTS LIST</b>	<b>53</b>

**CONTROL UNIT ASSEMBLIES**

Key	Description
1	Control Head Group Heater
2	Feed Group
3	Transmission Group

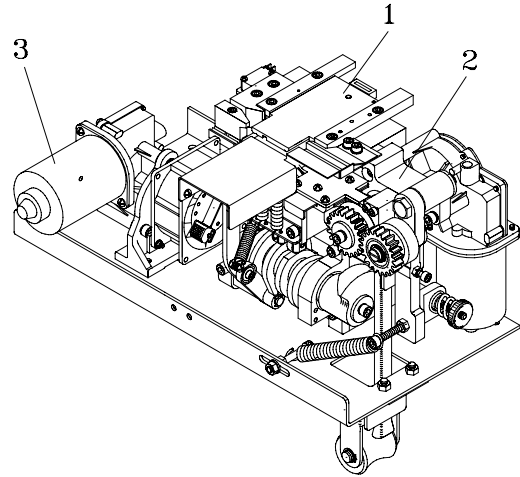

**Table-Tyer Strapping Head**

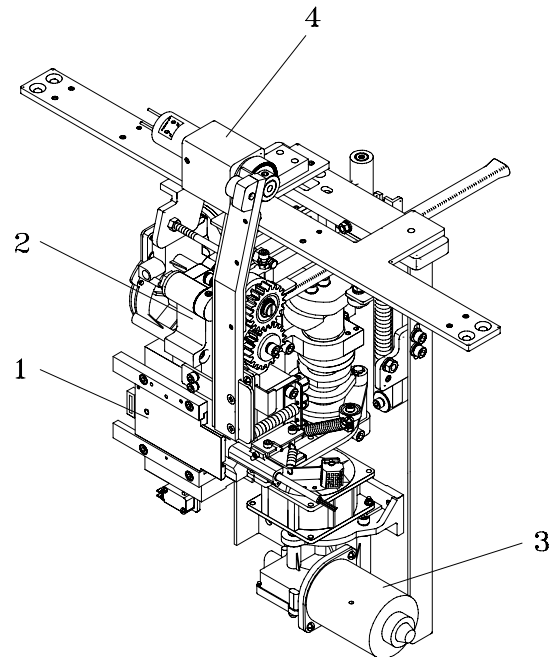

**Table-Tyer SS Strapping Head**

**CONTROL HEAD GROUP ASSEMBLY**

KEY	QTY	PART NO.	DESCRIPTION
1	1	500475	Main Body Block
2	1	500476	Switch Lever
3	1	500477	Switch Pin
4	1	500478	Strap Guide (A)
5	1	500479	Strap Guide (B)
6	1	500480	Switch Bracket
7	1	500481	Cutter Holder
8	1	500482	Bar Guide Lid
9	1	500483	Spring Hook
10	1	500484	Shaft
11	1	500485	Arm
12	1	500486	Return Spring
13	2	500487	Collar
14	1	500488	Slide
15	1	500489	Separator
16	1	500490	Guide (L)
17	1	500491	Guide (R)
18	1	500492	Gum
19	1	500493	Front Plate
20	1	500494	Guide Front
21	4	500495	HBS, M6x16
22	4	500496	HBS, M5x12
23	1	500497	HBS, M5x25
24	1	500498	Bearing 635ZZ
25	4	500499	PW,M5
26	1	500500	SW,M5
27	2	500501	I-IN, M5
28	1	500502	PMS, M4x20
29	1	500503	HN,M4
30	1	500504	Spring Pin, 6x20
31	2	500505	HSS, M6x6
32	2	500506	HN,M8
33	1	500507	SW,M8
34	4	500508	SW,M6
35	3	500509	Spring Pin, 3x12
36	1	500510	HBS, M5x5
37	1	500511	HBS, M4x25
38	3	500512	HBS, M5x16
39	2	500513	HBS, M5x8
41	1	500514	Cam Group (Table-Tyer)
	1	500880	Cam Group (Table-Tyer SS)
42	1	430700	Heater Assy
43	1	500516	Rear Bar Assy
44	1	500517	Press Bar Assy
45	1	500518	Front Bar Assy
46	1	500519	Transmission Group
51	1	500520	HBS,M5
52	2	500521	PMS, M3x20
53	3	500522	Micro Switch
54	2	500523	PW, M3
55	4	500524	SW, M3
56	2	500525	HN, M3
57	2	500526	PW, M4
58	2	500527	SW, M4
59	2	500528	PMS, M4x12
60	1	500529	Snap Ring E3
61	1	500530	Slide (For Small Package)
62	1	500531	Separator (For Small Package)

**⚠ WARNING**

Inspect all parts daily and replace them if they are worn or broken. Failure to do this can affect a product's operation and could result in serious personal injury.



**KEY QTY PART NO. DESCRIPTION**

63	1	500532	Switch Lever (For Small Package)
64	1	500533	Cutter Holder (For Small Package)
65	2	500534	Switch Trigger
66	2	500535	PMS, M3x35
67	1	500536	Plate
68	2	500537	Spring Pin, 5x12
69	1	500538	Safety Switch Plate
70	1	500539	Safety
71	1	500540	Switch Cover
72	2	500541	PMS, M4x30

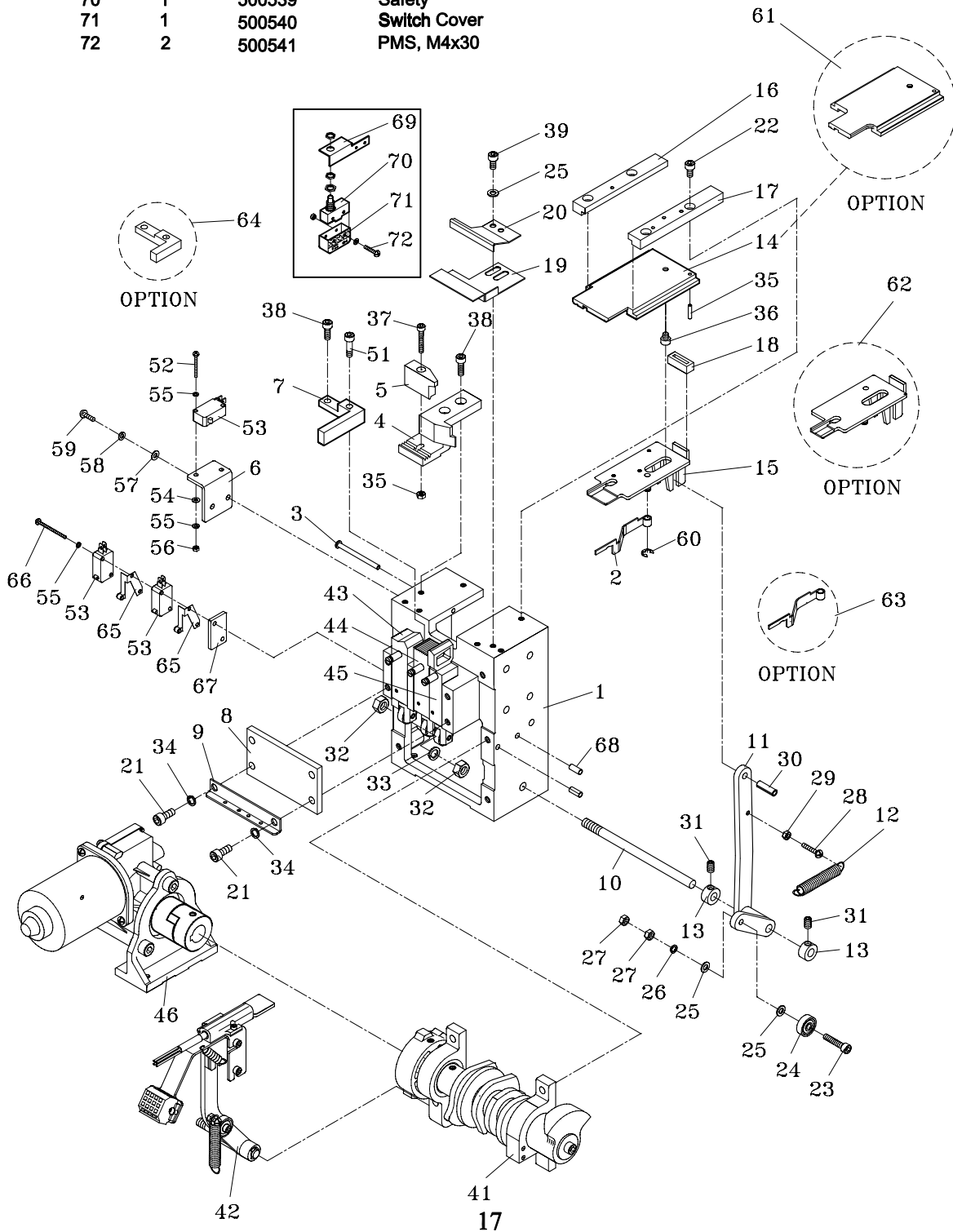

**CAM ASSEMBLIES**

KEY	QTY	Table-Tyer PART NO.	Table-Tyer SS PART NO.	DESCRIPTION
2	1	500543	500543	Cam Shaft
3	1	500544	500879	Tension Cam
4	1	500545	500545	Limit Switch Contactor
5	1	500546	500546	Bearing Support (L)
6	1	500547	500547	Bearing Support (R)
7	1	500548	500548	Washer
8	2	500549	500549	Ball Bearing, 6003ZZ
9	1	500550	500550	Key, 5x5x20
10	1	500551	500551	Key, 5x5x35
11	5	500505	500505	HBS, M6x6
12	1	500495	500495	HBS, M6x16
13	3	500552	500552	HBS, M6x20
14	1	500553	500553	HBS, M6x45
15	5	500508	500508	SW, M6
16	1	500899	500899	HSS, M6x10
17	1	500898	500898	Key, 5x5x101
18	5	500897	500897	HSS, M6x8
19	3	500896	500896	Spacer
20	1	500895	500895	Grip Cam
21	1	500894	500894	Grip Cam
22	1	500893	500893	Grip Cam
23	1	500892	500892	Grip Cam
24	1	500891	500891	Cam Separator
25	1	-	500878	Cam

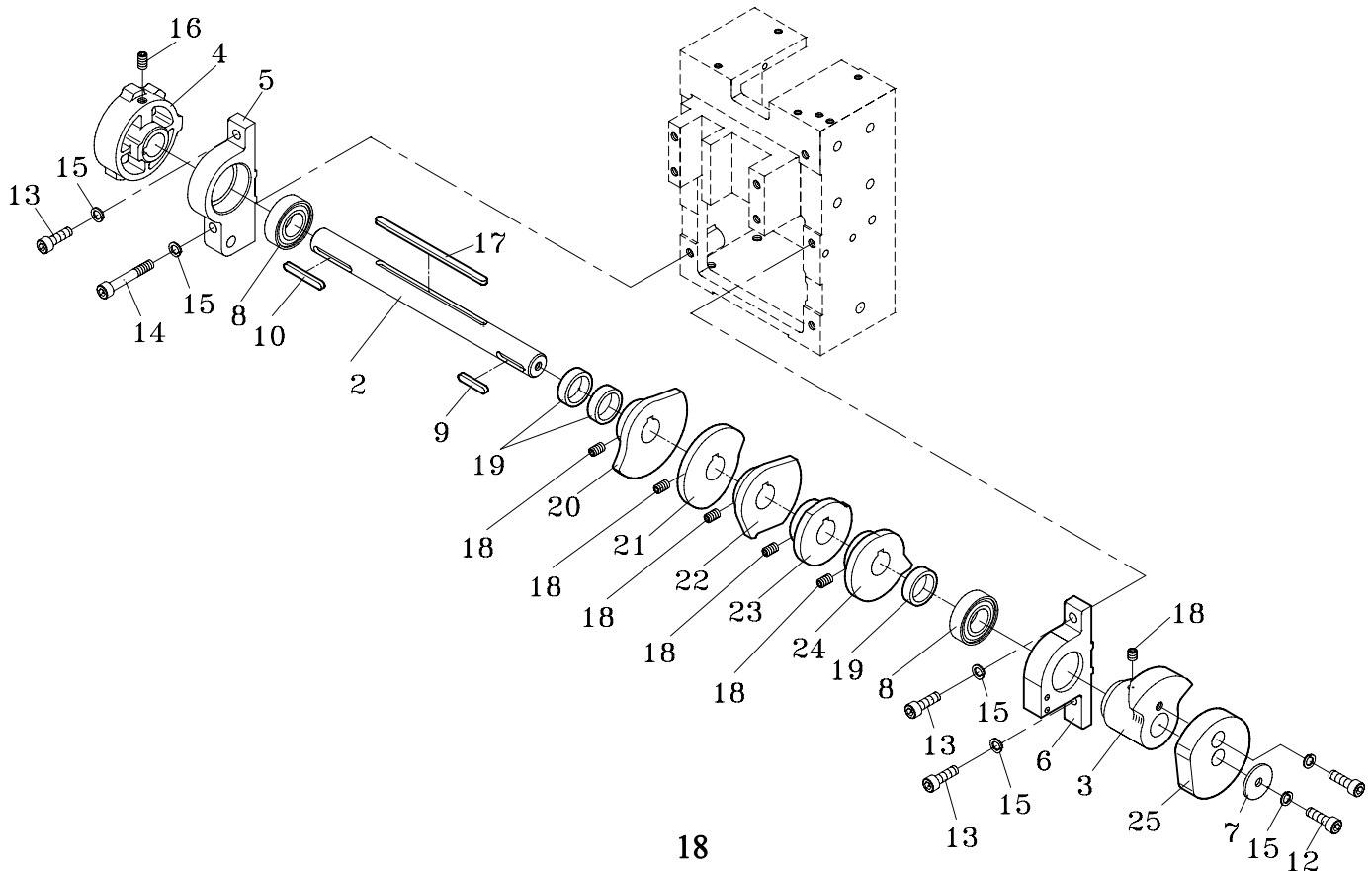

## HEATER ASSEMBLY

KEY	QTY	PART NO.	DESCRIPTION
1	1	500554	Heater Tongue
2	1	430701	Heater Bracket
3	1	500556	Heater Arm
4	1	500557	Pin
5	1	500558	Side Plate
6	1	500559	Return Spring
7	1	500560	Spring
8	2	500561	HBS, M4x40 (SUS)
9	2	500526	PW, M4
10	6	500527	SW, M4
11	7	500503	HN, M4
12	1	500512	HBS, M5x16
13	1	500562	Bearing, 635ZZ
14	1	500499	PW, M5
15	1	500563	HN, M5
16	1	500564	Snap Ring E6
17	5	500528	PMS, M4x12
18	1	500565	Heater Tongue (For Small Package)
19	1	500566	PW, M8
20	1	500506	HN, M8
21	1	500567	TMS, M3x6
22	1	500568	Heater
23	1	430702	Heat-Insulation
24	2	500495	HBS, M6x16
25	2	500508	SW, M6
26	1	500570	Fan Support
27	1	500571	Fan
28	1	430703	Fan Cover
29	1	500573	HBS, M3x8 (SUS)
30	1	500574	SW, M3 (SUS)
31	1	430707	Heater Terminal
32	1	430708	PMS, M4x20

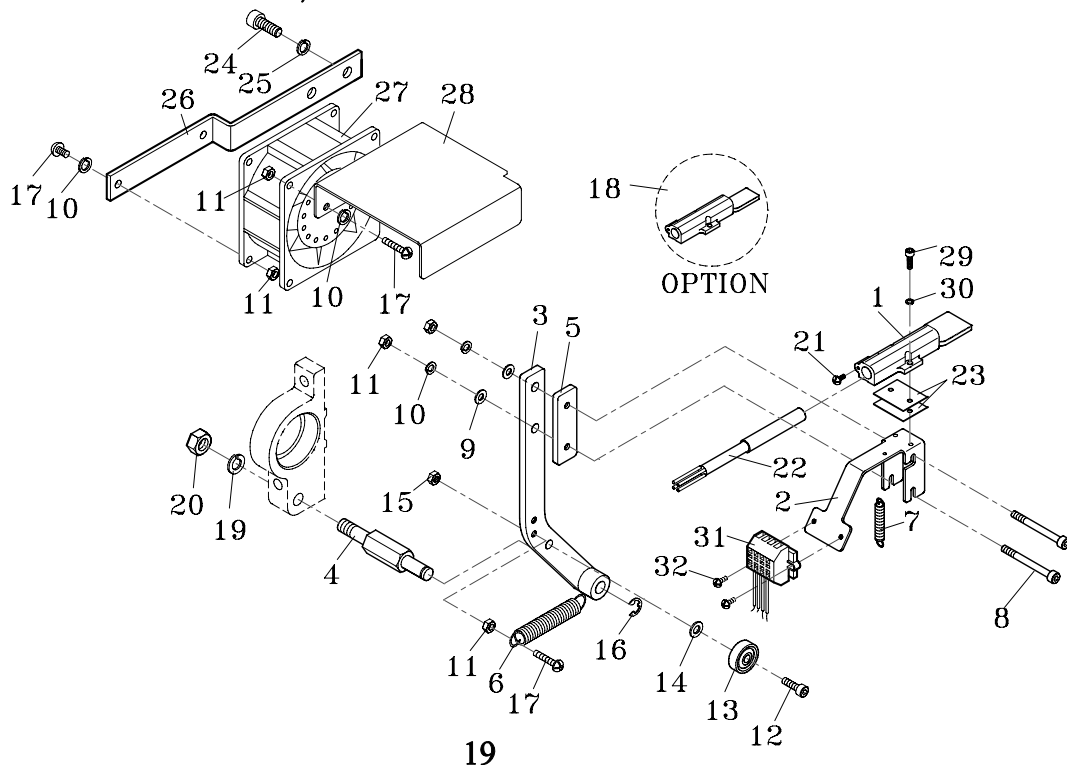

## REAR BAR ASSEMBLY

KEY	QTY	PART NO.	DESCRIPTION
1	1	500575	Spring Pin, 3x18
2	1	500576	Return Spring
3	1	500577	Spring Hook
4	1	500578	Rear Bar
5	1	500579	Plunger
6	1	500580	Bearing, 635ZZ
7	1	500581	Spring Pin, 5x14
8	1	500582	Spring
9	1	500583	Rear Bar (For Small Package)

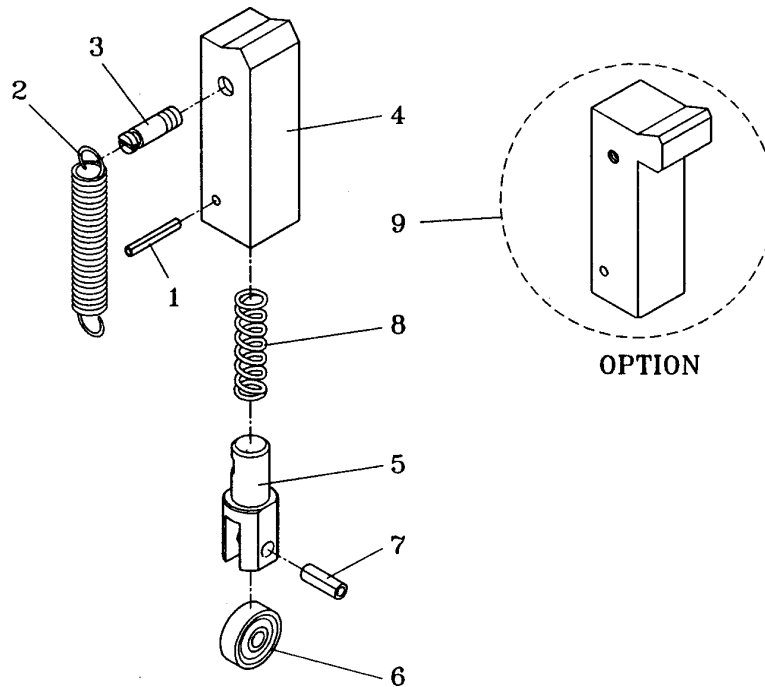

### **⚠ WARNING**

Inspect all parts daily and replace them if they are worn or broken. Failure to do this can affect a product's operation and could result in serious personal injury.

**PRESS BAR ASSEMBLY**

KEY	QTY	PART NO.	DESCRIPTION
1	1	500584	Press Bar
2	1	500575	Spring Pin, 3x18
3	1	500576	Return Spring
4	1	500577	Spring Hook
5	1	500578	Plunger
6	1	500579	Bearing, 635ZZ
7	1	500580	Spring Pin, 5x14
8	1	500581	Spring
9	1	500586	Press Bar (For Small Package)

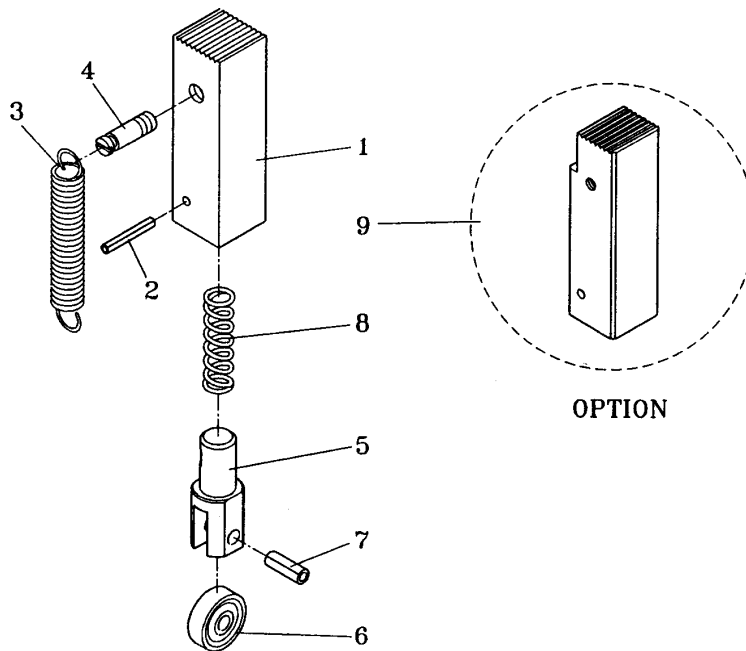
**⚠ WARNING**

Inspect all parts daily and replace them if they are worn or broken. Failure to do this can affect a product's operation and could result in serious personal injury.

## FRONT BAR ASSEMBLY

KEY	QTY	PART NO.	DESCRIPTION
1	1	500575	Spring Pin, 3x18
2	1	500576	Return Spring
3	1	500577	Spring Hook
4	1	500578	Plunger
5	1	500579	Bearing, 635ZZ
6	1	500580	Spring Pin, 5x14
7	1	500581	Spring
8	1	500587	Front Bar

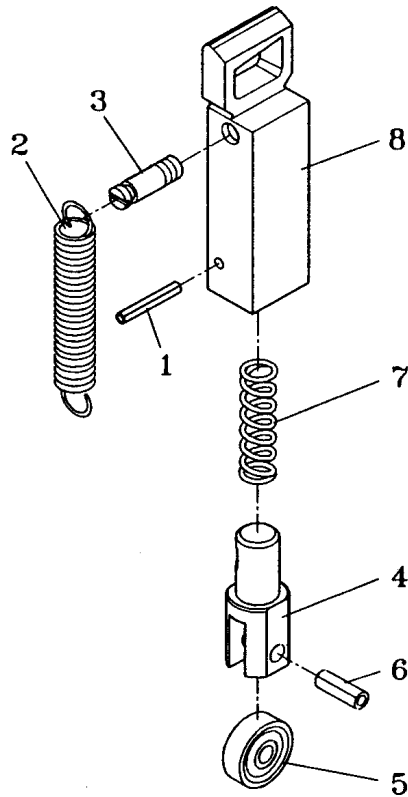

## **⚠ WARNING**

Inspect all parts daily and replace them if they are worn or broken. Failure to do this can affect a product's operation and could result in serious personal injury.

**FEED ASSEMBLY**

KEY	QTY	PART NO.	DESCRIPTION
1	1	500588	Bracket
2	1	500589	Motor Assy (M2)
3	1	500590	Key, 3x10
4	3	500552	HBS, M6x20
5	2	500591	HBS, M6x50
6	1	500592	HBS, M6x35
7	6	500508	SW, M6
8	2	500593	TMS, M5x10
9	2	500594	HBS, M5x25
10	2	500500	SW, M5
41	1	500595	Main Roller Assy
42	1	500596	Roller Arm Assy (Table-Tyer)
	1	500596	Roller Arm Assy (Table-Tyer SS)
43	1	500597	Feed Shooter Assy (Table-Tyer)
	1	500876	Feed Shooter Assy (Table-Tyer SS)
44	1	430704	Strap Guide Assy
45	1	500889	Plastic drive gear w/ shaft (only)

**⚠ WARNING**

Inspect all parts daily and replace them if they are worn or broken. Failure to do this can affect a product's operation and could result in serious personal injury.

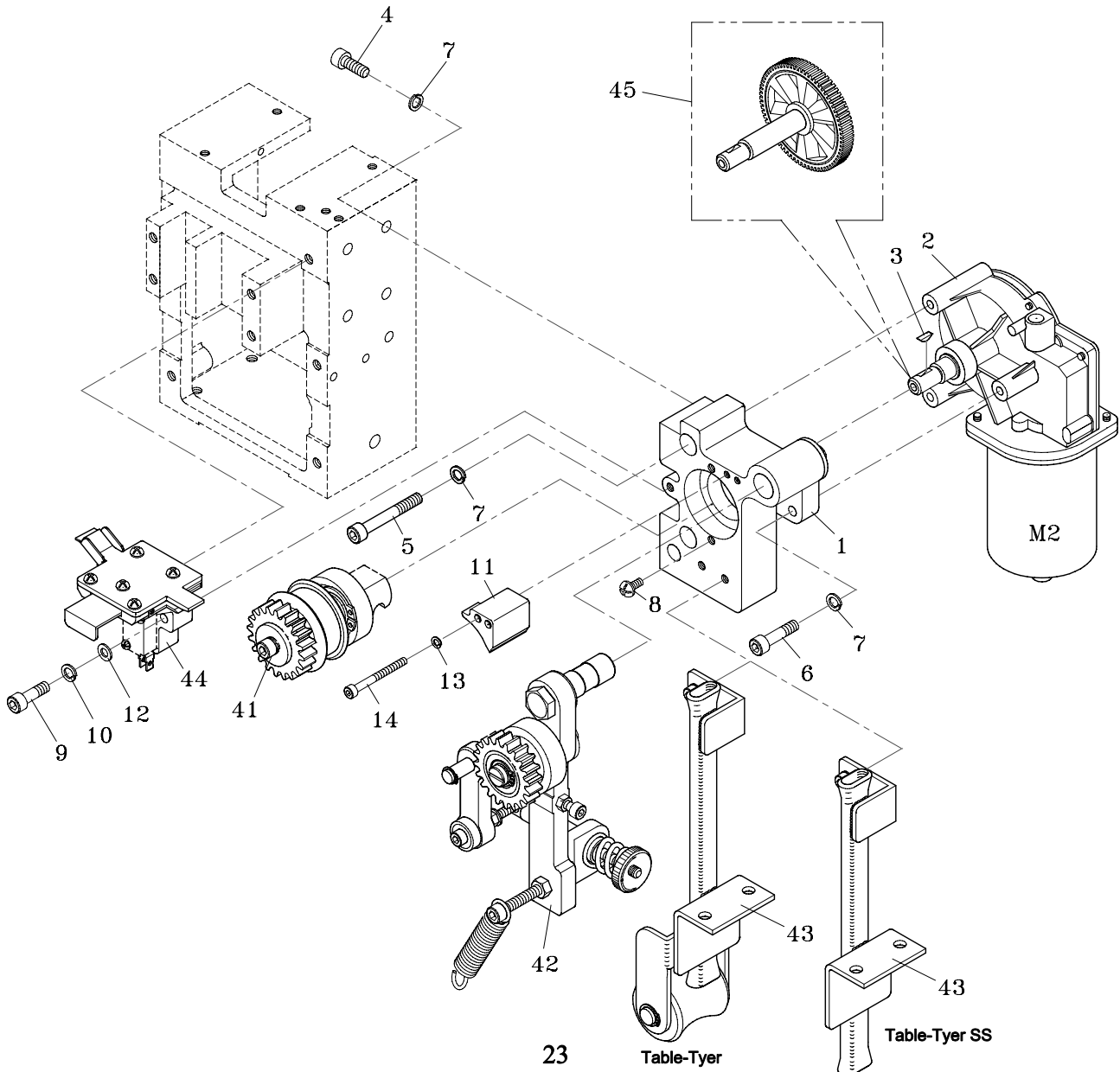

**MAIN ROLLER ASSEMBLY**

KEY	QTY	PART NO.	DESCRIPTION
1	1	500599	Main Roller Shaft
2	1	500600	Main Roller
3	2	500601	Side Plate
4	1	500602	Bearing, 6004ZZ
5	1	500603	Stop Ring, S-20
6	1	500604	Gear
7	1	500605	Washer
8	1	500508	SW, M6
9	1	500495	HBS, M6x16
10	1	500496	HBS, M5x12
11	1	500606	Key 5x5x35

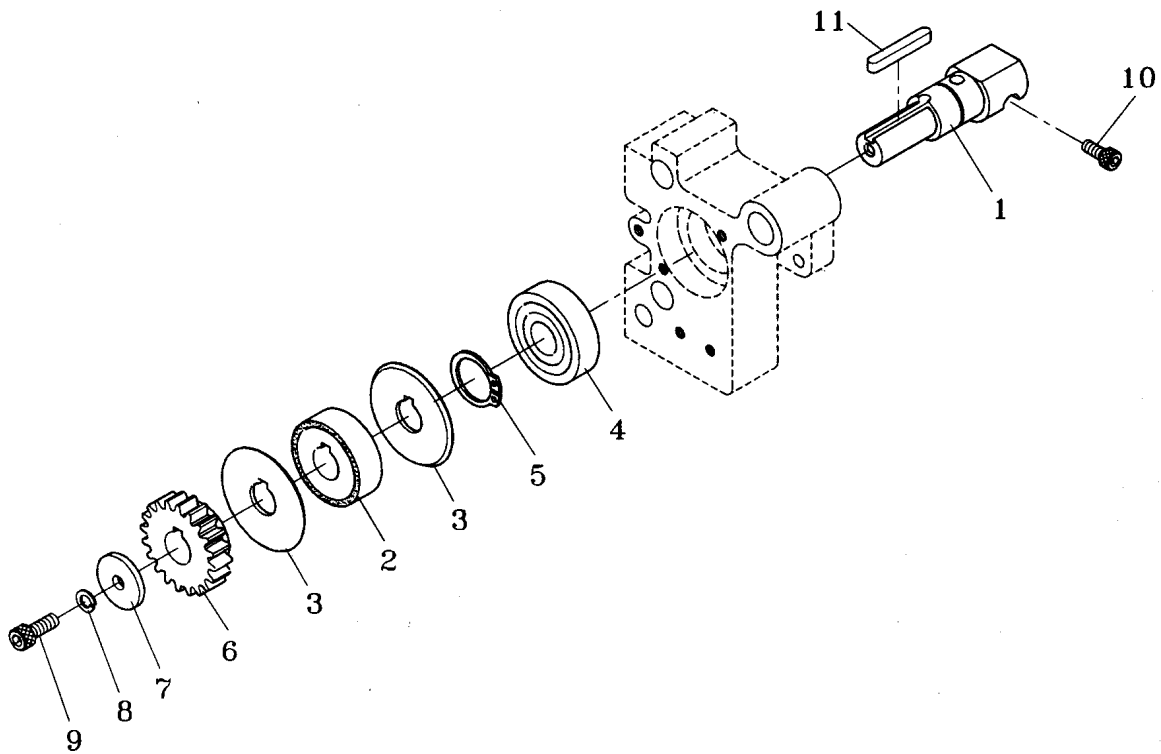
**⚠ WARNING**

Inspect all parts daily and replace them if they are worn or broken. Failure to do this can affect a product's operation and could result in serious personal injury.



**FEED SHOOTER ASSEMBLY 500597, TABLE-TYER**

KEY	QTY	PART NO.	DESCRIPTION
1	1	500628	Feed Shooter
2	2	500500	SW,M5
3	2	500512	HBS, M5x16
4	2	500629	Ring, S10
5	1	500630	Shaft
6	1	500631	Roller
7	4	500632	PW,M6
8	2	500508	SW,M6
9	2	500495	HBS, M6x16
10	2	500633	HN,M6

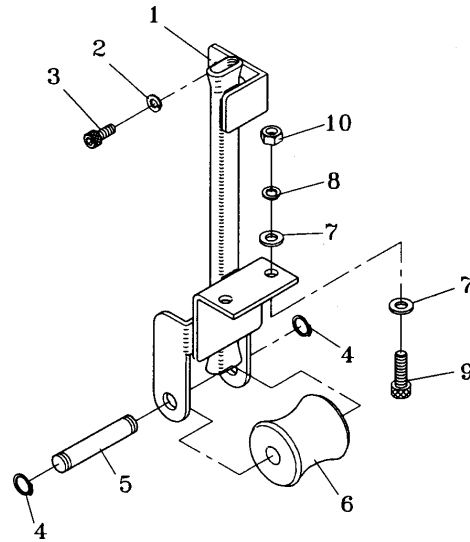
**FEED SHOOTER ASSEMBLY 500876, TABLE-TYER SS**

KEY	QTY	PART NO.	DESCRIPTION
1	1	500874	Feed Shooter
2	2	500500	SW,M5
3	2	500512	HBS, M5x16
7	4	500632	PW,M6
8	2	500508	SW,M6
9	2	500495	HBS, M6x16
10	2	500633	HN,M6

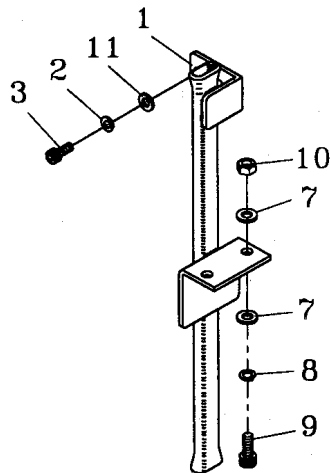

## ROLLER ARM ASSEMBLY

KEY	QTY	500596 PART NO.	500877 PART NO.	DESCRIPTION
1	1	500607	500607	Tension Arm
2	1	500508	500508	Shaft
3	1	500609	500609	Connect Rod
4	1	500610	500610	Roller Arm
5A	1	500611	~	Shaft (Table-Tyer)
5B	1	~	500875	Shaft (Table-Tyer SS)
6	1	500612	500612	Spring
7	1	500613	500613	Roller Shaft
8	1	500614	500614	Roller
9	1	430705	430705	Feed Spring
10	2	500616	500616	Washer
11	1	500617	500617	Nut
12	1	500618	500618	Name Plate
13	1	500619	500619	HBS, M6x75
14	1	500620	500620	HN, M6
15	2	500495	500495	HBS, M6x16
16	3	500508	500508	SW, M6
17	2	500621	500621	Bearing, 6001ZZ
18	1	500622	500622	Snap Ring S12
19	1	500505	500505	HSS, M5x5
20	1	500623	500623	HBS, M5x40
21	1	500624	500624	Bearing, 635ZZ
22	3	500499	500499	PW, M5
23	4	500563	500563	HN, M5
24	1	500500	500500	SW, M5
25	2	500625	500625	Snap Ring E6
26	2	500626	500626	Bushing
27	1	500627	500627	HBS, M5x30

### **⚠ WARNING**

**Inspect all parts daily and replace them if they are worn or broken. Failure to do this can affect a product's operation and could result in serious personal injury.**

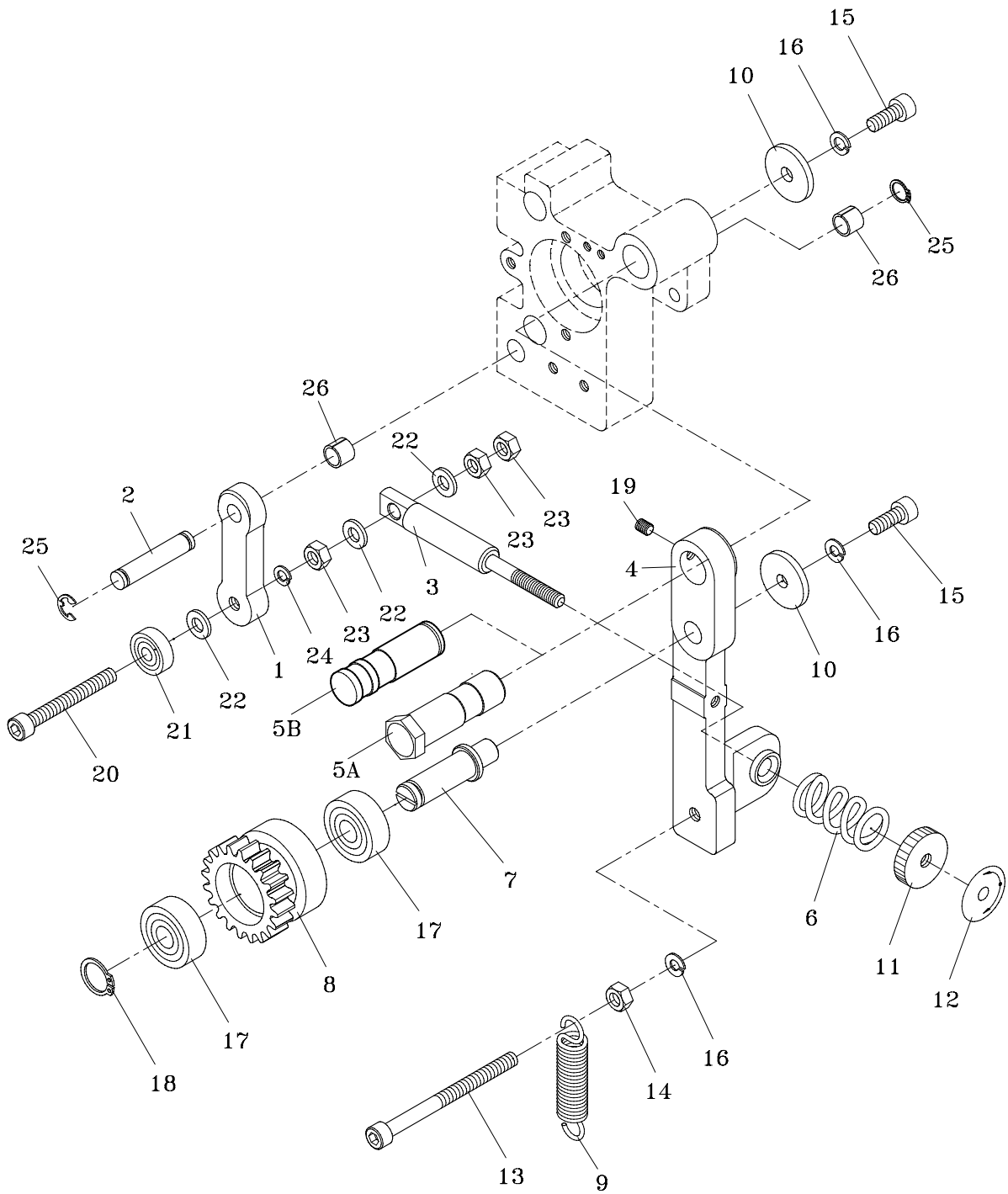

## STRAP GUIDE ASSEMBLY

KEY	QTY	PART NO.	DESCRIPTION
1	1	500634	Strap Guide Support
2	1	500635	Strap Guide (A)
3	1	500636	Strap Guide (B)
4	1	500637	Strap Guide Cover (For 8-12mm)
5	1	500638	Strap Guide (C)
6	1	500639	Spring
7	1	500640	Strap Guide Cover (For 5-7mm)
8	2	500641	PMS, M3x15
9	1	500642	HBS, M4x40
10	1	500526	PW, M4
11	1	500503	HN, M4
12	5	500528	PMS, M4x12
13	2	500524	SW, M3
14	1	500643	Micro Switch
15	5	500527	SW, M4

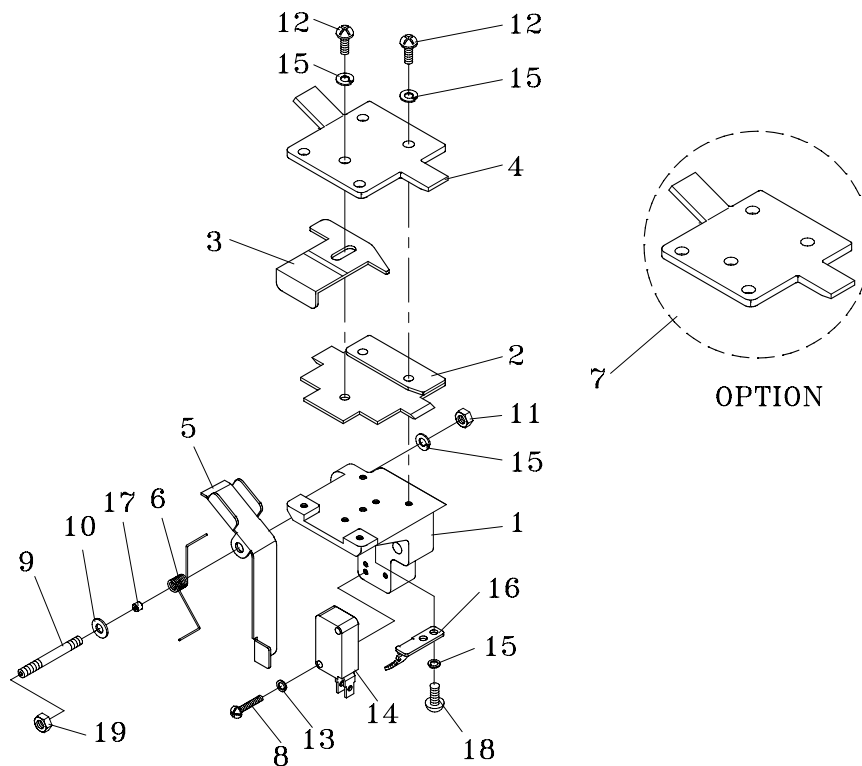

## WARNING

Inspect all parts daily and replace them if they are worn or broken. Failure to do this can affect a product's operation and could result in serious personal injury.

## TRANSMISSION ASSEMBLY

KEY	QTY	PART NO.	DESCRIPTION
1	1	500644	Main Motor Support
2	1	500645	Shaft Coupling
3	1	500646	Main Motor Assy (M1)
4	4	500512	HBS, M5x16
5	3	500647	HBS, M6x25
6	6	500508	SW, M6
7	1	500648	Key, 3x10
8	4	500500	SW, M5
9	3	500649	PW, M6 (A)
10	1	500890	Plastic drive gear w/ shaft
11	3	430557	HBS, M6x16
12	3	430558	PW, M6 (C)
13	1	430559	Flexible Coupling
14	1	430560	Hub (L.H.)
15	1	430561	Flexible Spacer
16	1	430562	Hub (R.H.)
17	4	430563	HSS, M6x8

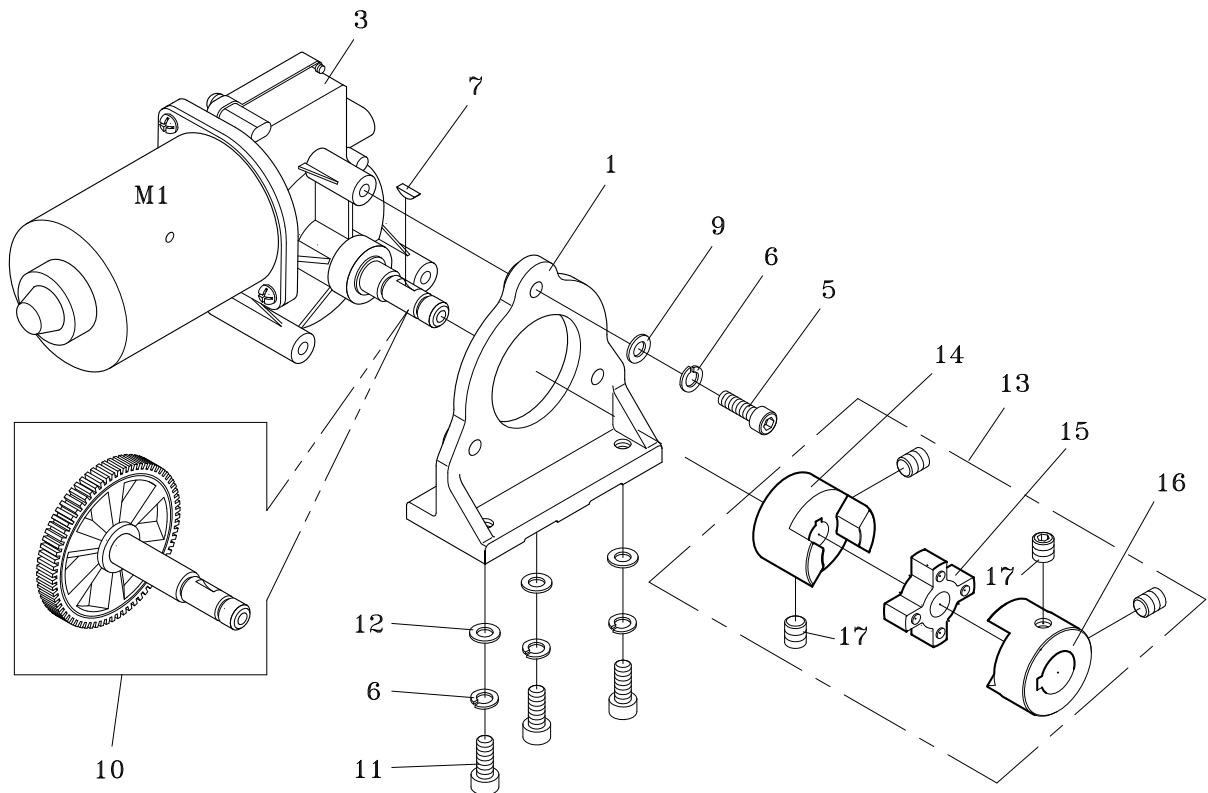

**⚠ WARNING**

Inspect all parts daily and replace them if they are worn or broken. Failure to do this can affect a product's operation and could result in serious personal injury.